

GR680-2700

**Maxium Reach:2715 mm /
Lemma Wrist / Max Payload:8 kg**

Highlights

Lemma wrist, no singularity in the front, especially suitable for painting for in-the-front workpiece;
The electric control cabinet complies with EN ISO13849 PLd security level and supports aux axis;
Standard painting application software, built-in I/Os, easy integration, simple programming;
ATEX explosion-proof certification of China and Eu, can be used in zone 1 gas and zone 21 dust dangerous operation environment.

Applications

Specially designed for irregular shape parts painting: such as engineering engines, engineering machinery accessories, etc;
Also can be used for multi-size regular parts painting, such as containers.

Industries

Suitable for auto parts, logistics and transportation industries.



EFORT INTELLIGENT EQUIPMENT CO.,LTD.
PHONE: (00 86) 400-052-8877
ADDRESS: No.96 East WanChun Road, JiuJiang Economic
Development Zone, Wuhu, Anhui, China
WWW.EFORT.COM.CN



SPECIFICATIONS

Wrist Payload	8 kg		
Reach	2715 mm		
Repeatability	± 0.2 mm		
Motion Range & Speed	Range	Speed	
	J1	± 175°	150°/s
	J2	+80°/-150°	145°/s
	J3	+125°/-80°	150°/s
	J4	± 360°	500°/s
	J5	± 360°	500°/s
Allowable Torque	J4	30 N.m	
	J5	25 N.m	
	J6	12 N.m	
Allowable Moment of Inertia	J4	0.8 kg.m ²	
	J5	0.59 kg.m ²	
	J6	0.1 kg.m ²	

OPERATING SPACE

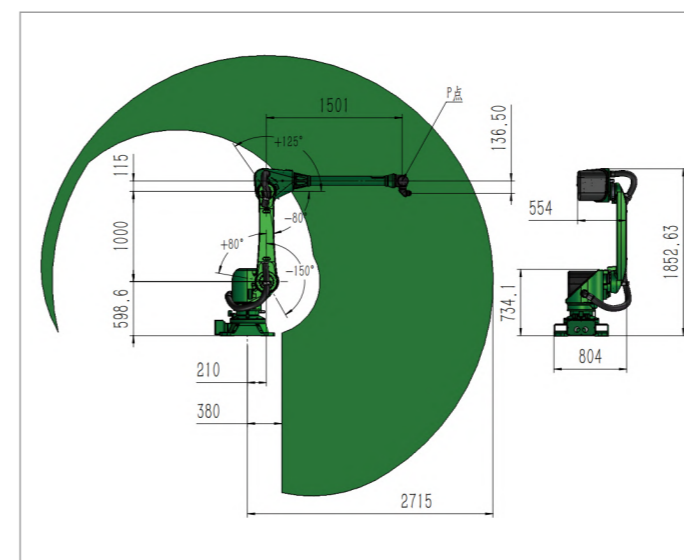

BASE & END FLANGE MOUNTING SIZE

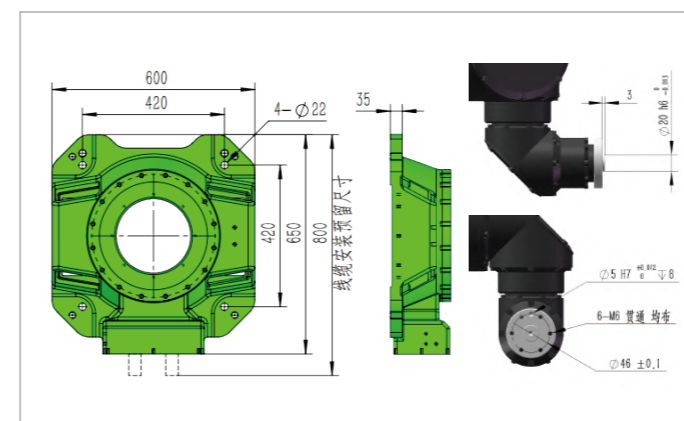

Structure	6-Axis Series Structure	
Installation	Floor, Angel, Wall, Upside-down	
Safety Level	EN ISO13849 PLd	
IP Grade	Robot	IP 65
	Cabinet	IP 54
Explosion-Proof	China	Ex d ib px IIB T4 Gb
	ATEX-Gas	II 2G Ex pxb IIB T4 Gb
	ATEX-Dust	II 2D Ex pxb IIIC T135°C Db
Environment Requirements	Voltage	AC380V (± 10%)
	Power Capacity	5.0 kVA
	Temperature	0-45 °C
Arm Payload	Outer Arm	8 kg
	Inner Arm	8 kg
	Humidity	20-80RH (No Condensation)
Weight	Robot	450 kg
	Cabinet	160 kg

CONTROL CABINET SIZE & WRIST END LOAD MAP

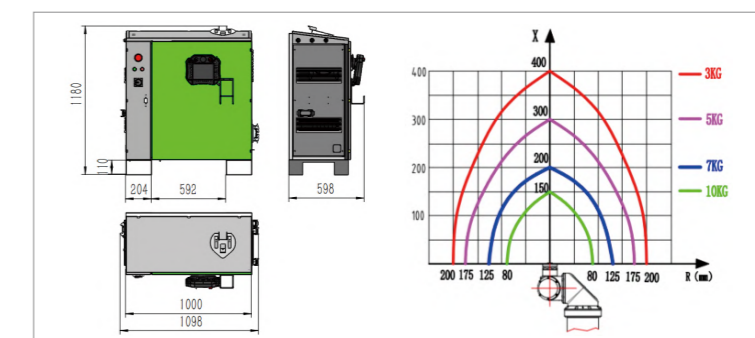

SELECTION & CONFIGURATION TABLE

Item	Standard	Optional	
Driver	6 Axes	6+2~4 Axes	
Connector Cable	Static	Static	Flexible
	8 m	Max:30 m	
Pendant	10 m	Max:30 m	
DI/DO	12/12	Customized	
Safety DI/DO	8/4	Customized	
AI/AO	/	Customized	
Communication Mode	TCP/IP	ProfiBus Slave	ProfiNet Slave
Memory Capacity	1GB	/	
Connector	USB/TCP/IP	/	
Software Package	Painting Package	Visual Programming	
Program Mode	Pendant	Touch Panel	
Color	RAL6018	Customized	