

EXR150-2700

EFORT

EXR150-2700,
Maxium payload 150 kg with maxium reach 2674 mm.

Highlights

Developed and designed based on EFORT's mature platform, it is stable and reliable;
Equipped with a battery-free encoder, featuring a fully sealed design, fully wrapped cables, and closed-loop explosion-proof control with a complete cavity, it is safer;
Explosion protection level: Ex db ib pxb IIC T5 Gb; Ex ib pxb tb IIIC T100°C Db. It can be used in hazardous environments in Zone 1 and Zone 21.

Applications

It can be applied to dust or gas explosion-proof scenarios in handling, sorting, assembly, grinding, polishing, spraying, and other applications.

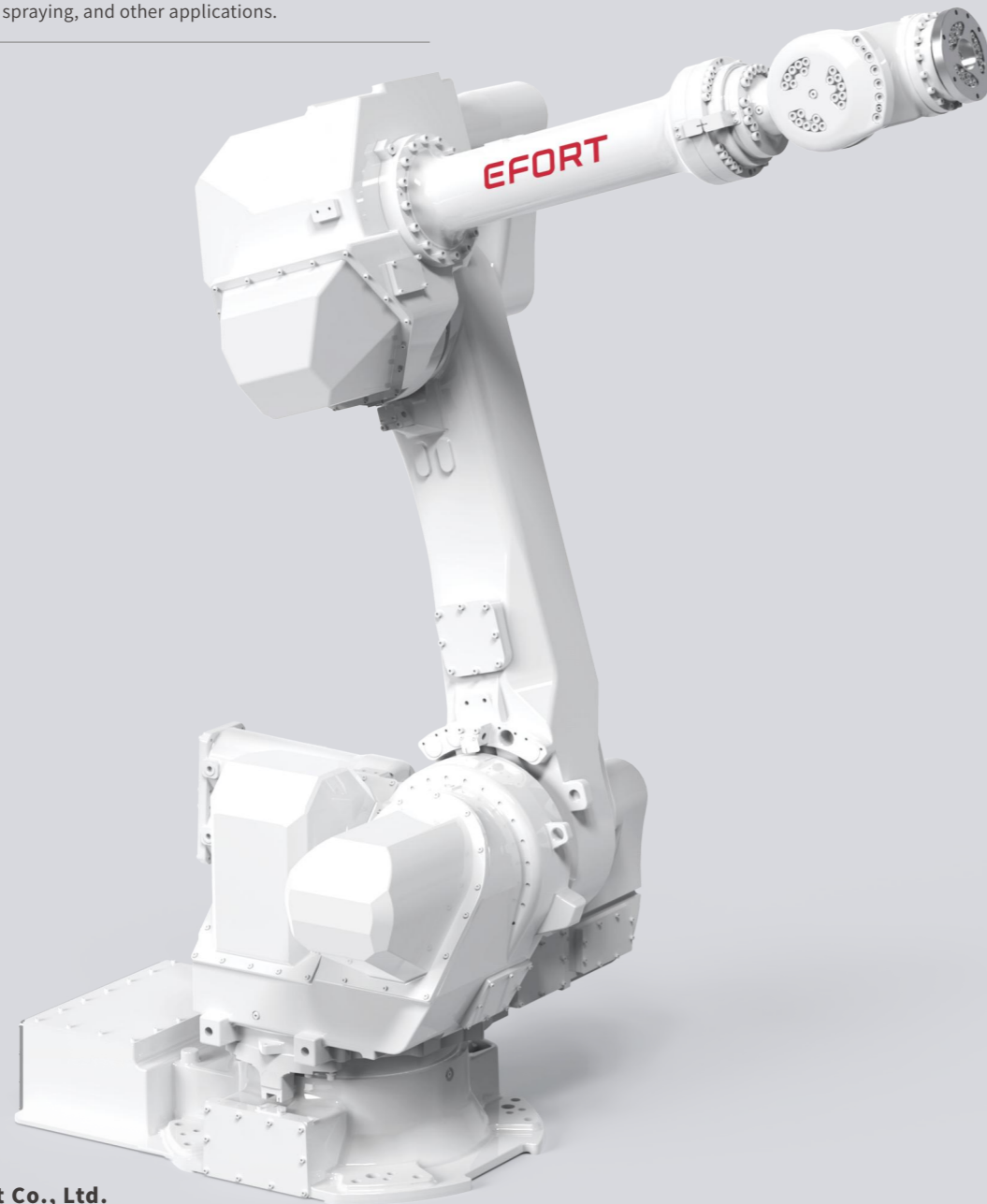

SPECIFICATIONS

Model	EXR150-2700	
Type	Articulated	
Controlled axes	6 Axes	
Max. payload on wrist	150 kg	
Repeatability	±0.06 mm	
Robot weight	1375 kg	
Reach	2674 mm	
Robot IP grade	IP65	
Cabinet IP grade	IP54	
Explosion protection level	Ex db ib pxb IIC T5 Gb Ex ib pxb tb IIIC T100°C Db	
Drive mode	AC servo drive	
Installation	Floor	
Installation environment	Ambient temperature	0~45 °C
	Ambient humidity	RH≤80% (No dew nor frost allowed)
	Vibration acceleration	4.9 m/s ² (<0.5 G)

Allowable load moment at wrist	J4	1337 N·m
	J5	1337 N·m
	J6	720 N·m
Allowable load inertia at wrist	J4	141.1 kg·m ²
	J5	141.1 kg·m ²
	J6	79 kg·m ²
Maximum speed	J1	100°/sec
	J2	90°/sec
	J3	85°/sec
	J4	109°/sec
	J5	105°/sec
	J6	200°/sec
Motion range	J1	±180°
	J2	+60°-80°
	J3	+90°-83°
	J4	±360°
	J5	±120°
	J6	±360°

OPERATING SPACE

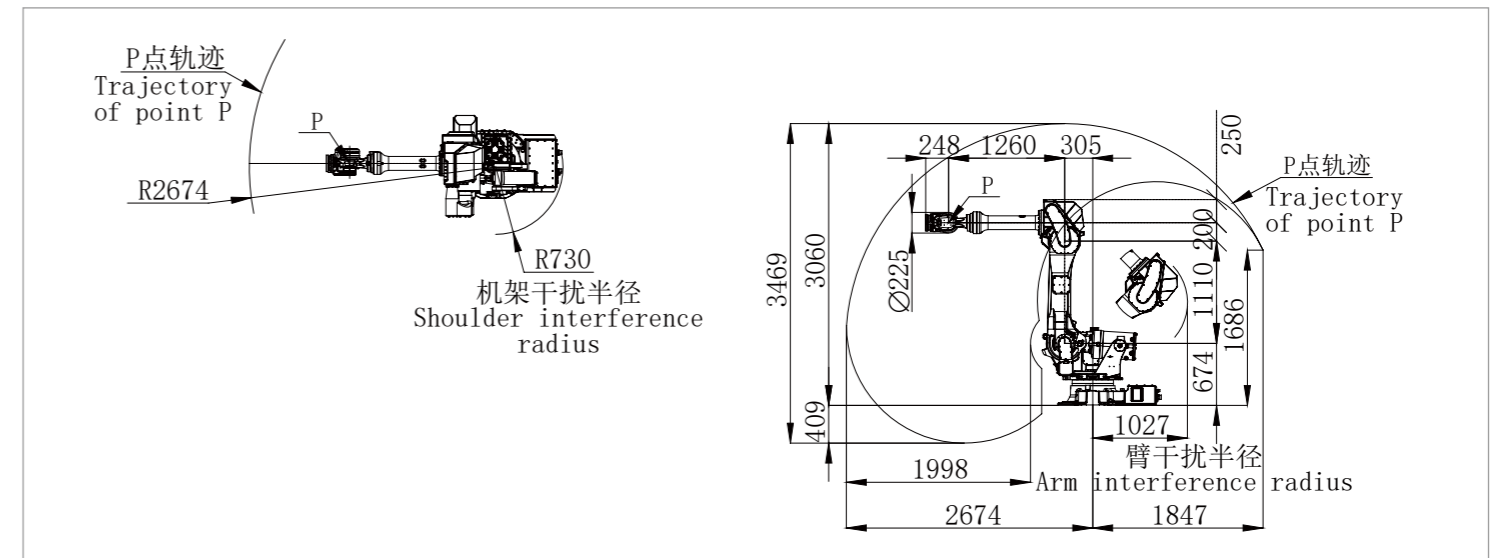

BASE MOUNTING SIZE

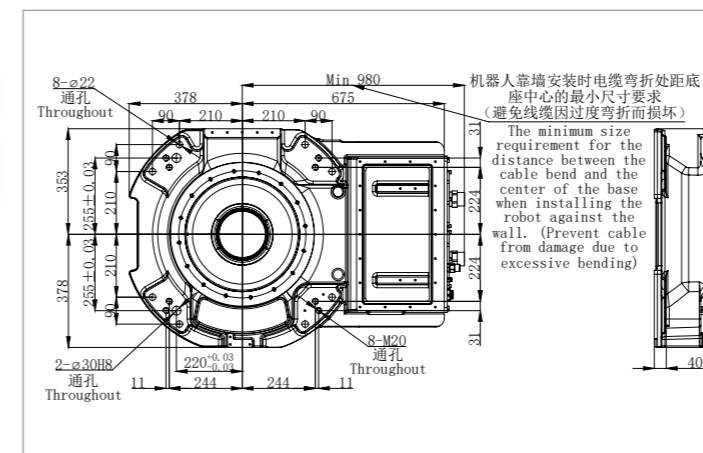

END FLANGE MOUNTING SIZE

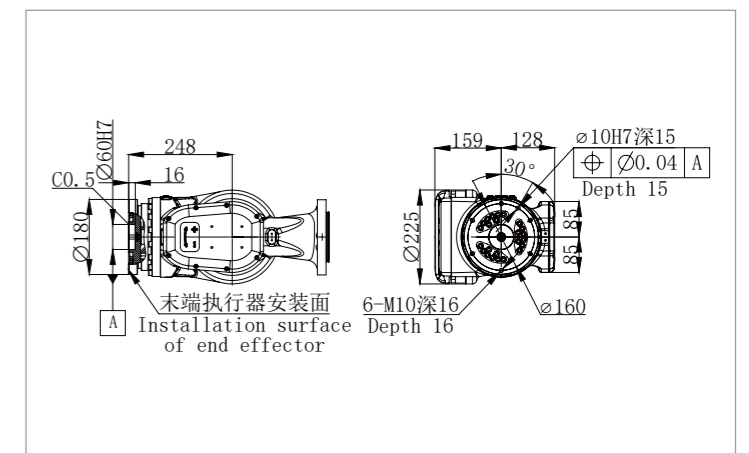

EFORT Intelligent Robot Co., Ltd.
PHONE: (00 86) 400-052-8877
ADDRESS: No. 96, Wanchun East Road, Wuhu, China
(Anhui) Pilot Free Trade Zone
WWW.EFORT.COM.CN