

EFORT

ESR3-400Z15

ESR3-400Z15,
Maxium payload 3 kg with maxium reach 400 mm.

- **Highlights**
 1. High rhythm and high precision
The fastest standard cycle time can reach 0.33 s, and the robot positioning accuracy can reach 0.01 mm.
 2. High rigidity and low vibration
Robot body mode and rigidity enhancement, combined with vibration suppression and active vibration suppression functions, effectively reduce vibration.
 3. Easy to maintain and scalable
The detachable structure of cables and batteries allows for the replacement of robots inside the device, and the built-in camera network cable enables various communication extensions.
- **Applications**
It can be used in handling, sorting, assembly, etc.
- **Industries**
Suitable for industries such as electronic manufacturing, lithium batteries, automotive electronics, and photovoltaics.



SPECIFICATIONS

Model		ESR3-400Z15
Reach		400 mm
Max. payload on wrist	Rated	1 kg
	Maximum	3 kg
Robot weight		12 kg
Maximum speed	J1+J2	7200 mm/sec
	J3	1100 mm/sec
	J4	3000°/sec
Motion range	J1	±132°
	J2	±145°
	J3	150 mm
	J4	±360°
Repeatability	J1+J2	±0.01 mm
	J3	±0.01 mm
	J4	±0.01°
Standard cycle time		0.33 s
J4 allowable moment of inertia	Rated	0.005 kg·m ²
	Maximum	0.05 kg·m ²
Electric lines		D-Sub 15-Pin
Pneumatic lines		φ4 mmx1, φ6 mmx2
J3 downward force		100 N
Installation		Floor
Installation enviroment	Ambient temperature	5~40°C
	Ambient humidity	RH≤80% (No dew nor frost allowed)

*The final interpretation right belongs to EFORT Intelligent Robot Co., Ltd. Any updates will be made without prior notice.

OPERATING SPACE

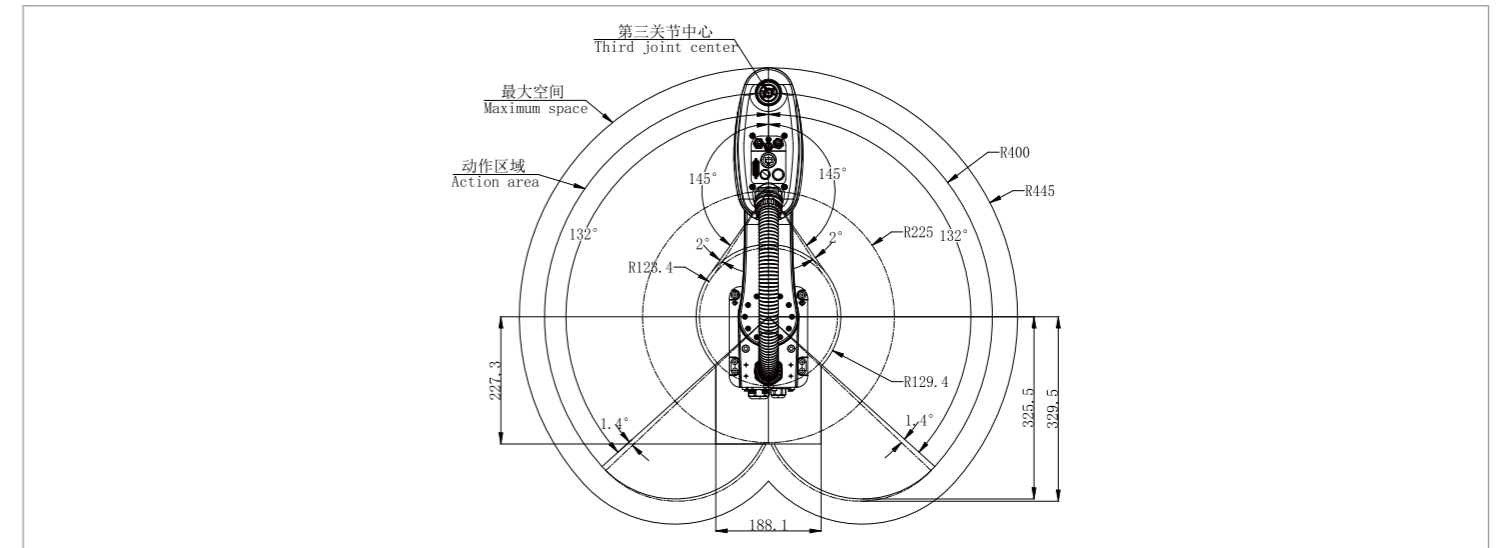

BASE MOUNTING SIZE

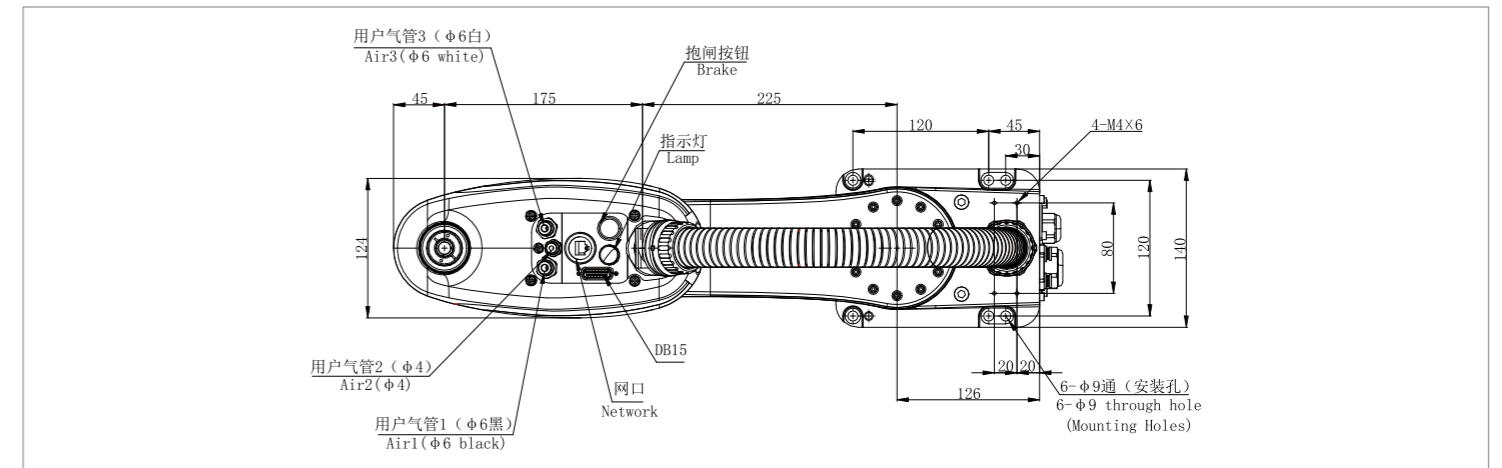

END FLANGE MOUNTING SIZE

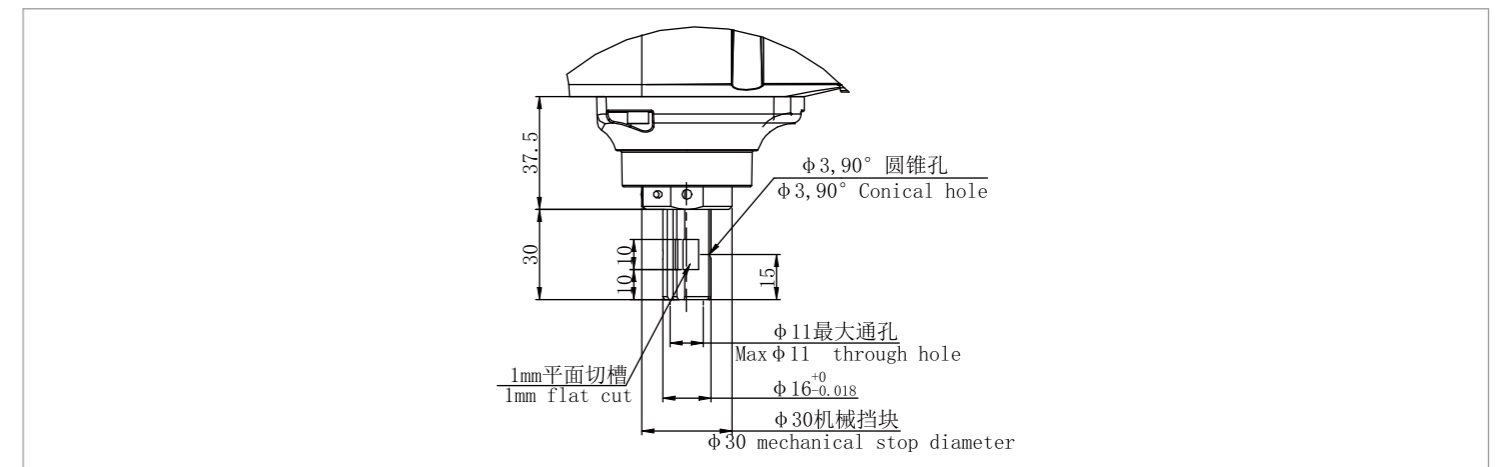

Information Release Time 2025/04

PHONE: (00 86) 400-052-8877
 ADDRESS: No. 96, Wanchun East Road, Wuhu,
 China (Anhui) Pilot Free Trade Zone
 WWW.EFORT.COM.CN

EFORT Intelligent Robot Co., Ltd.