

# ER35-1800

**EFORT**

**ER35-1800,**  
Maxium payload 35 kg with maxium reach 1851 mm.

## ■ Highlights

Thanks to the new design of wrist, inertia and bearing capacity are increased by 25% with wider application scope;  
Thanks to the high stiffness transmission design and advanced trajectory algorithm, the improved robot accuracy performance helps customers to face variety of application scenarios;  
Lighter weight of the body, 20% less than its predecessor.

## ■ Applications

It can be used in handling operations, assembling, grinding, polishing, deburring, etc.

## ■ Industries

Suitable for metal parts, photovoltaic, logistics, food and beverage and other industries.



## SPECIFICATIONS

<b>Model</b>	ER35-1800	
<b>Type</b>	Articulated	
<b>Controlled axes</b>	6 Axes	
<b>Max. payload on wrist</b>	35 kg	
<b>Repeatability</b>	±0.05 mm	
<b>Robot weight</b>	259 kg	
<b>Reach</b>	1851 mm	
<b>Robot IP grade</b>	IP54	
<b>Cabinet IP grade</b>	IP20/ IP54 (Optional)	
<b>Drive mode</b>	AC servo drive	
<b>Installation</b>	Floor, Upside-down	
<b>Installation enviroment</b>	<b>Ambient temperature</b>	0~45 °C
	<b>Ambient humidity</b>	RH≤80% (No dew nor frost allowed)
	<b>Vibration acceleration</b>	4.9 m/s <sup>2</sup> (<0.5 G)

<b>Allowable load moment at wrist</b>	<b>J4</b>	110 N·m
	<b>J5</b>	110 N·m
	<b>J6</b>	60 N·m
<b>Allowable load inertia at wrist</b>	<b>J4</b>	4 kg·m <sup>2</sup>
	<b>J5</b>	4 kg·m <sup>2</sup>
	<b>J6</b>	2 kg·m <sup>2</sup>
<b>Maximum speed</b>	<b>J1</b>	220°/sec
	<b>J2</b>	180°/sec
	<b>J3</b>	200°/sec
	<b>J4</b>	350°/sec
	<b>J5</b>	350°/sec
	<b>J6</b>	410°/sec
<b>Motion range</b>	<b>J1</b>	±170°
	<b>J2</b>	+77°-160°
	<b>J3</b>	+156°-85°
	<b>J4</b>	±190°
	<b>J5</b>	±130°
	<b>J6</b>	±360°

## OPERATING SPACE

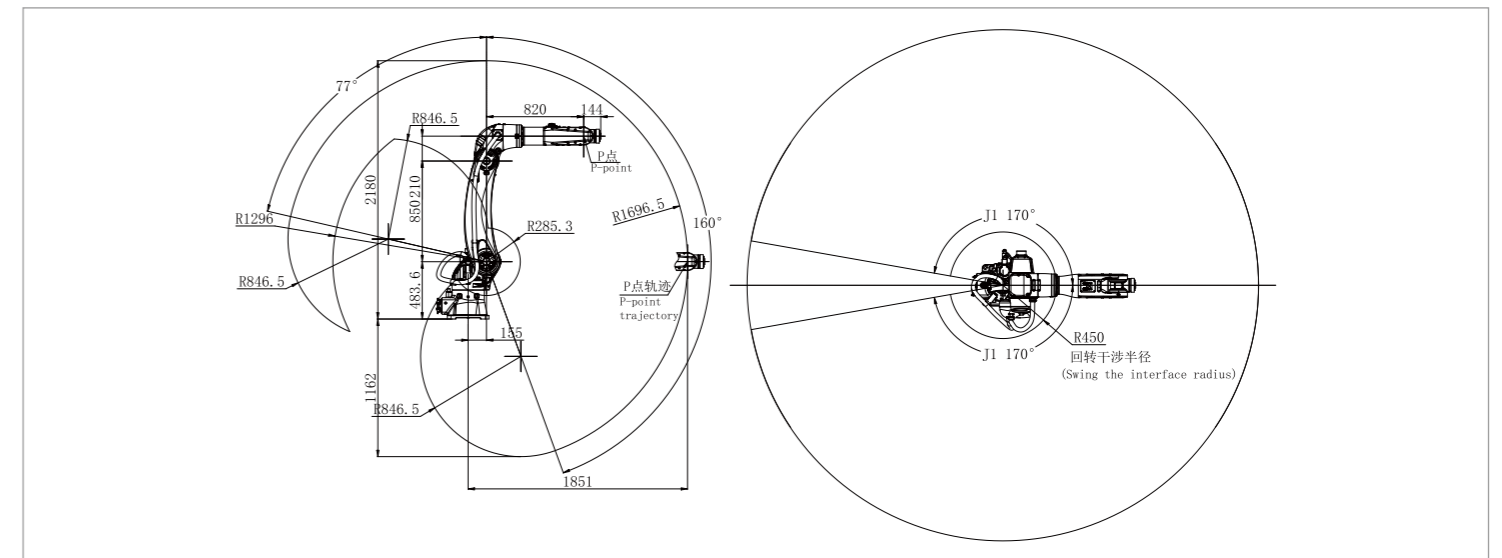

## BASE MOUNTING SIZE

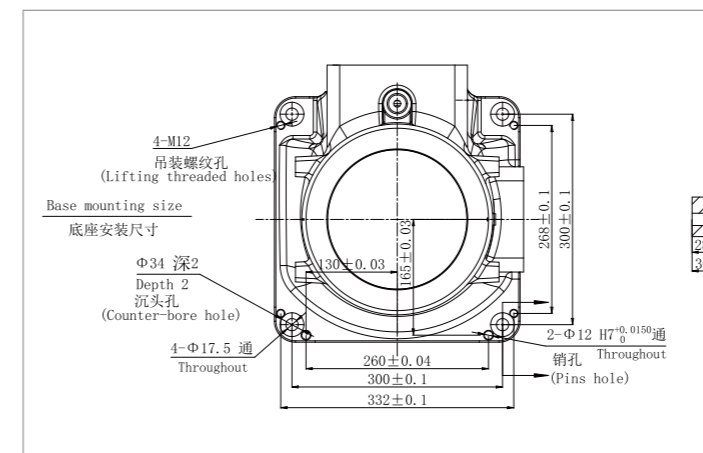

## END FLANGE MOUNTING SIZE

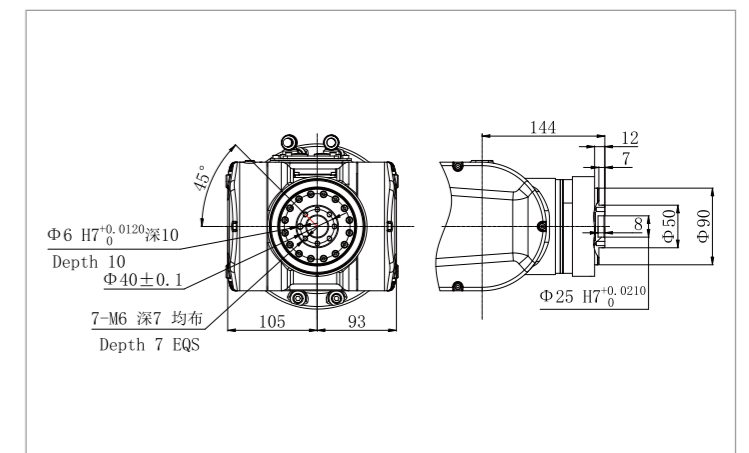

**EFORT Intelligent Robot Co., Ltd.**

PHONE: (00 86) 400-052-8877

ADDRESS: No. 96, Wanchun East Road, Wuhu, China

(Anhui) Pilot Free Trade Zone

WWW.EFORT.COM.CN

\*The final interpretation right belongs to EFORT Intelligent Robot Co., Ltd. Any updates will be made without prior notice.

Information Release Time 2026/03