

# ER25-2700

**EFORT**

**ER25-2700,**  
Maxium payload 25 kg with maxium reach 2701 mm.

## Highlights

Thanks to the high stiffness structure, with high-speed intelligent palletizing application software, the takt is improved by 20%, bring customers more efficiency;  
Multiple specific application software could be integrated, with soft PLC and a variety of field bus interface, which enable customers easily face various application challenges;  
High performance collision detection function helps safety realization.

## Applications

It can be used in handling operations, palletizing, etc.

## Industries

Suitable for metal parts, auto parts, logistics, ceramics, cement, food and beverage and other industries.



**EFORT Intelligent Robot Co., Ltd.**

PHONE: (00 86) 400-052-8877  
ADDRESS: No. 96, Wanchun East Road, Wuhu, China  
(Anhui) Pilot Free Trade Zone  
WWW.EFORT.COM.CN

## SPECIFICATIONS

<b>Model</b>	ER25-2700	
<b>Type</b>	Articulated	
<b>Controlled axes</b>	6 Axes	
<b>Max. payload on wrist</b>	25 kg	
<b>Repeatability</b>	±0.05 mm	
<b>Robot weight</b>	375 kg	
<b>Reach</b>	2701 mm	
<b>Robot IP grade</b>	IP54	
<b>Cabinet IP grade</b>	IP20/ IP54 (Optional)	
<b>Drive mode</b>	AC servo drive	
<b>Installation</b>	Floor, Upside-down	
<b>Installation enviroment</b>	<b>Ambient temperature</b>	0~45 °C
	<b>Ambient humidity</b>	RH≤80% (No dew nor frost allowed)
	<b>Vibration acceleration</b>	4.9 m/s <sup>2</sup> (<0.5 G)

<b>Allowable load moment at wrist</b>	<b>J4</b>	50 N·m
	<b>J5</b>	50 N·m
	<b>J6</b>	30 N·m
<b>Allowable load inertia at wrist</b>	<b>J4</b>	2.2 kg·m <sup>2</sup>
	<b>J5</b>	2.2 kg·m <sup>2</sup>
	<b>J6</b>	1.5 kg·m <sup>2</sup>
<b>Maximum speed</b>	<b>J1</b>	190°/sec
	<b>J2</b>	150°/sec
	<b>J3</b>	200°/sec
	<b>J4</b>	400°/sec
	<b>J5</b>	400°/sec
	<b>J6</b>	440°/sec
<b>Motion range</b>	<b>J1</b>	±173°
	<b>J2</b>	+70°-150°
	<b>J3</b>	+147°-90°
	<b>J4</b>	±190°
	<b>J5</b>	±130°
	<b>J6</b>	±360°

## OPERATING SPACE

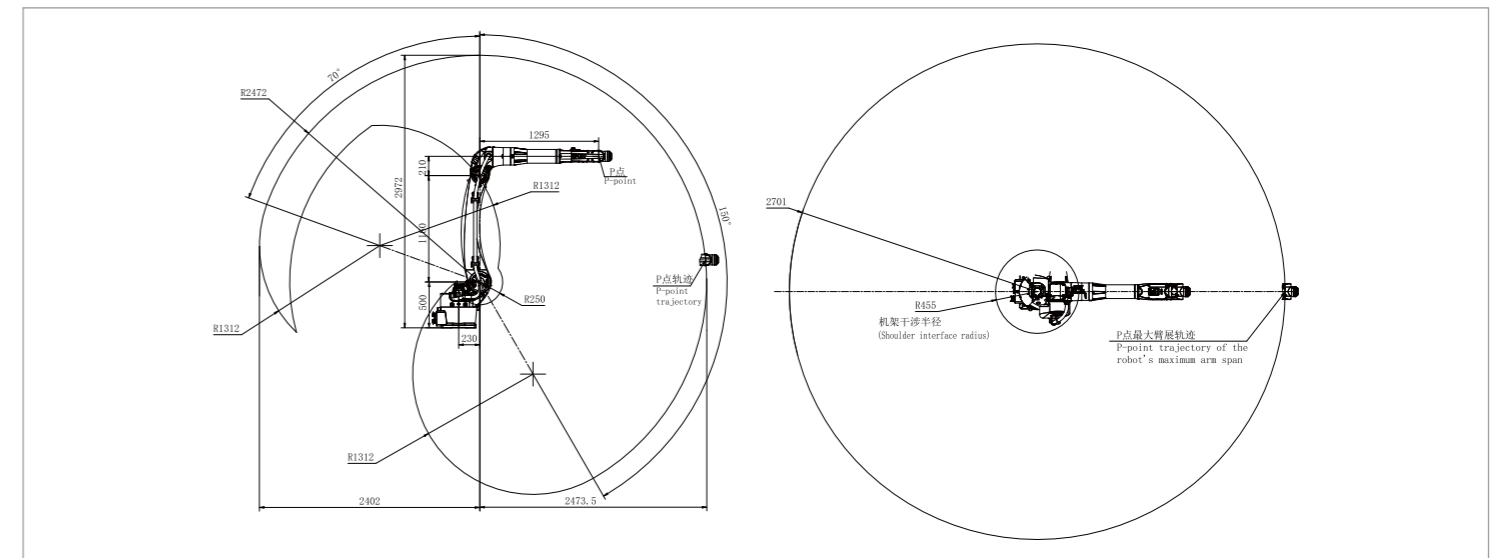

## BASE MOUNTING SIZE

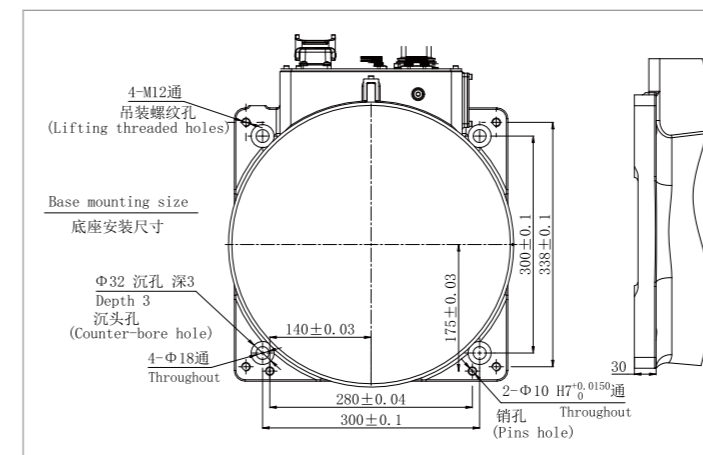

## END FLANGE MOUNTING SIZE

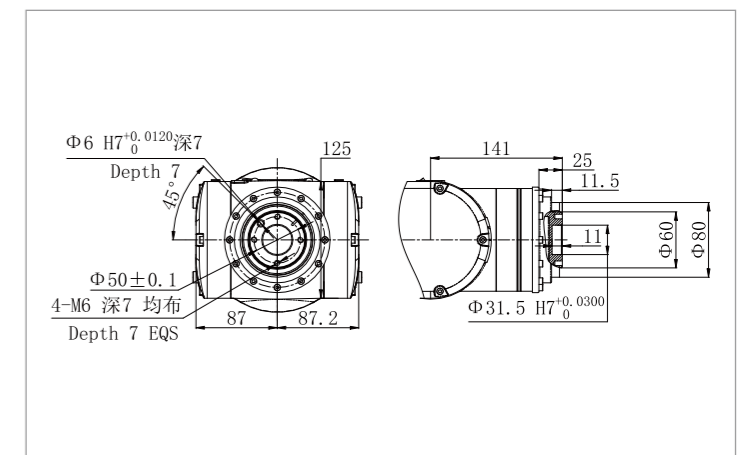

\*The final interpretation right belongs to EFORT Intelligent Robot Co., Ltd. Any updates will be made without prior notice.