

ER25-1600

EFORT

ER25-1600,
Maxium payload 25 kg with maxium reach 1665 mm.

Highlights

Thanks to the new design of wrist, inertia and bearing capacity are increased by 25% with wider application scope;
Thanks to the high stiffness transmission design and advanced trajectory algorithm, the improved robot accuracy performance helps customers to face variety of application scenarios;
Lighter weight of the body, 20% less than its predecessor.

Applications

It can be used in handling operations, assembling, grinding, polishing, deburring, etc.

Industries

Suitable for metal parts, photovoltaic, logistics, food and beverage and other industries.



SPECIFICATIONS

Model	ER25-1600	
Type	Articulated	
Controlled axes	6 Axes	
Max. payload on wrist	25 kg	
Repeatability	±0.05 mm	
Robot weight	215 kg	
Reach	1665 mm	
Robot IP grade	IP54 / IP67 (Wrist)	
Cabinet IP grade	IP20/ IP54 (Optional)	
Drive mode	AC servo drive	
Installation	Floor, Upside-down, Wall	
Installation enviroment	Ambient temperature	0~45 °C
	Ambient humidity	RH≤80% (No dew nor frost allowed)
	Vibration acceleration	4.9 m/s ² (<0.5 G)

Allowable load moment at wrist	J4	50 N·m
	J5	50 N·m
	J6	30 N·m
Allowable load inertia at wrist	J4	2.2 kg·m ²
	J5	2.2 kg·m ²
	J6	1.5 kg·m ²
Maximum speed	J1	220°/sec
	J2	180°/sec
	J3	200°/sec
	J4	360°/sec
	J5	360°/sec
	J6	410°/sec
Motion range	J1	±170°
	J2	+77°-160°
	J3	+165°-85°
	J4	±190°
	J5	±130°
	J6	±360°

OPERATING SPACE

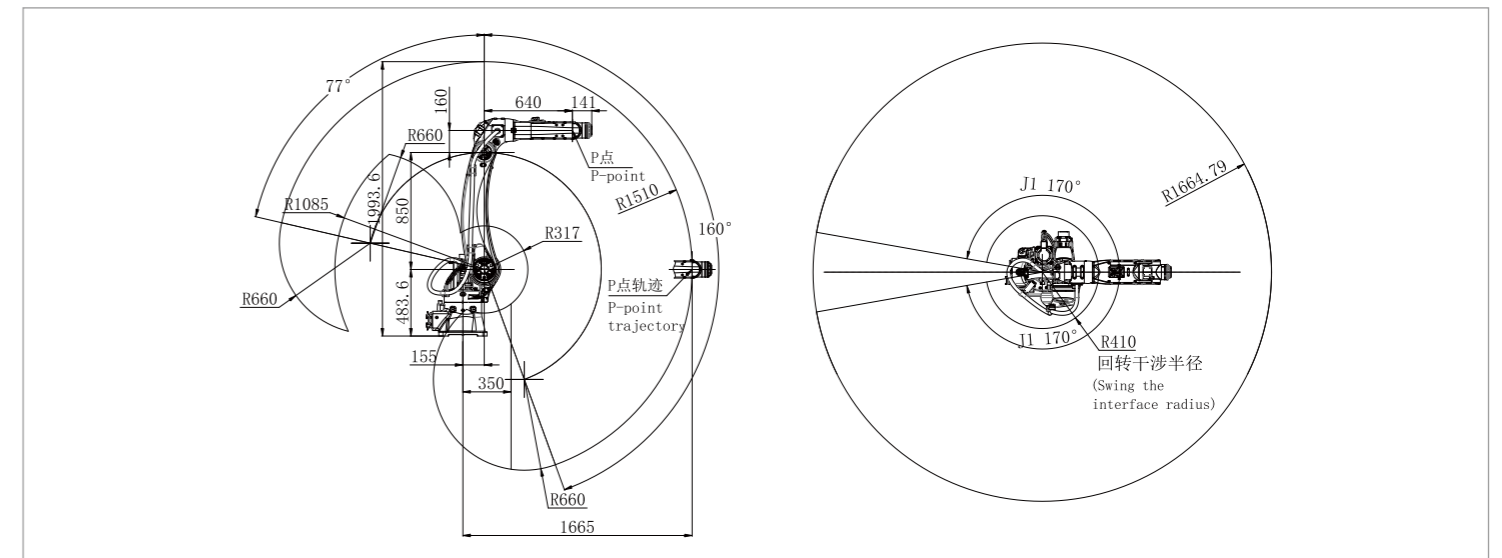

BASE MOUNTING SIZE

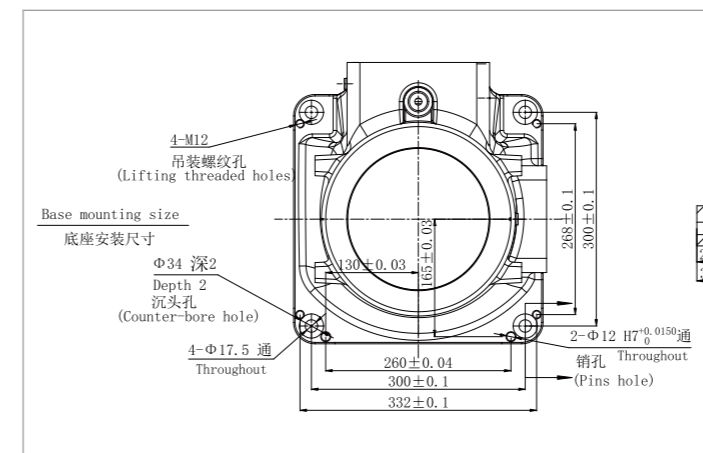

END FLANGE MOUNTING SIZE

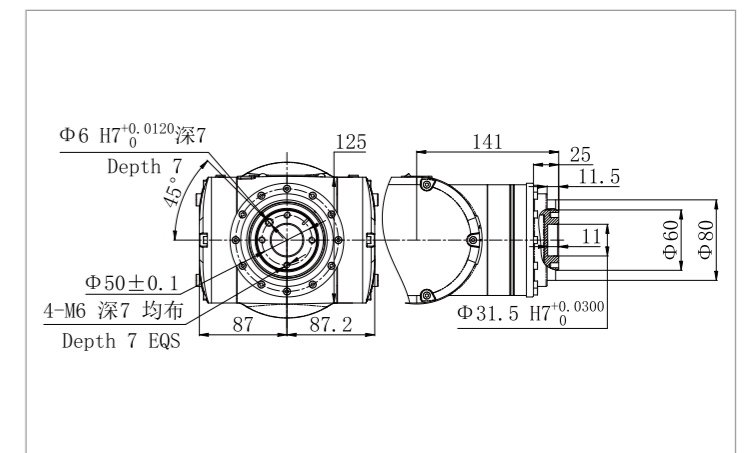

EFORT Intelligent Robot Co., Ltd.

PHONE: (00 86) 400-052-8877
ADDRESS: No. 96, Wanchun East Road, Wuhu, China
(Anhui) Pilot Free Trade Zone
WWW.EFORT.COM.CN

*The final interpretation right belongs to EFORT Intelligent Robot Co., Ltd. Any updates will be made without prior notice.

Information Release Time 2026/03