

ER100P-3500

EFORT

ER100P-3500,
Maxium payload 100 kg with maxium reach 3502 mm.

■ **Highlights**

Platform-based products and modular design make customer spare parts management more flexible;
With a working radius of 3500mm and a maximum downward reach of 2567mm, the robot can flexibly access the interior of equipment to perform tasks such as part retrieval and cleaning;
The balance cylinder utilizes a nitrogen-liquid hybrid design, eliminating the need for nitrogen gas refilling, ensuring enhanced stability, improved durability, and an extended service life.

■ **Applications**

It can be applied to elevated platform scenarios, such as die casting and injection molding.

■ **Industries**

Suitable for fields like automotive and home appliance manufacturing.

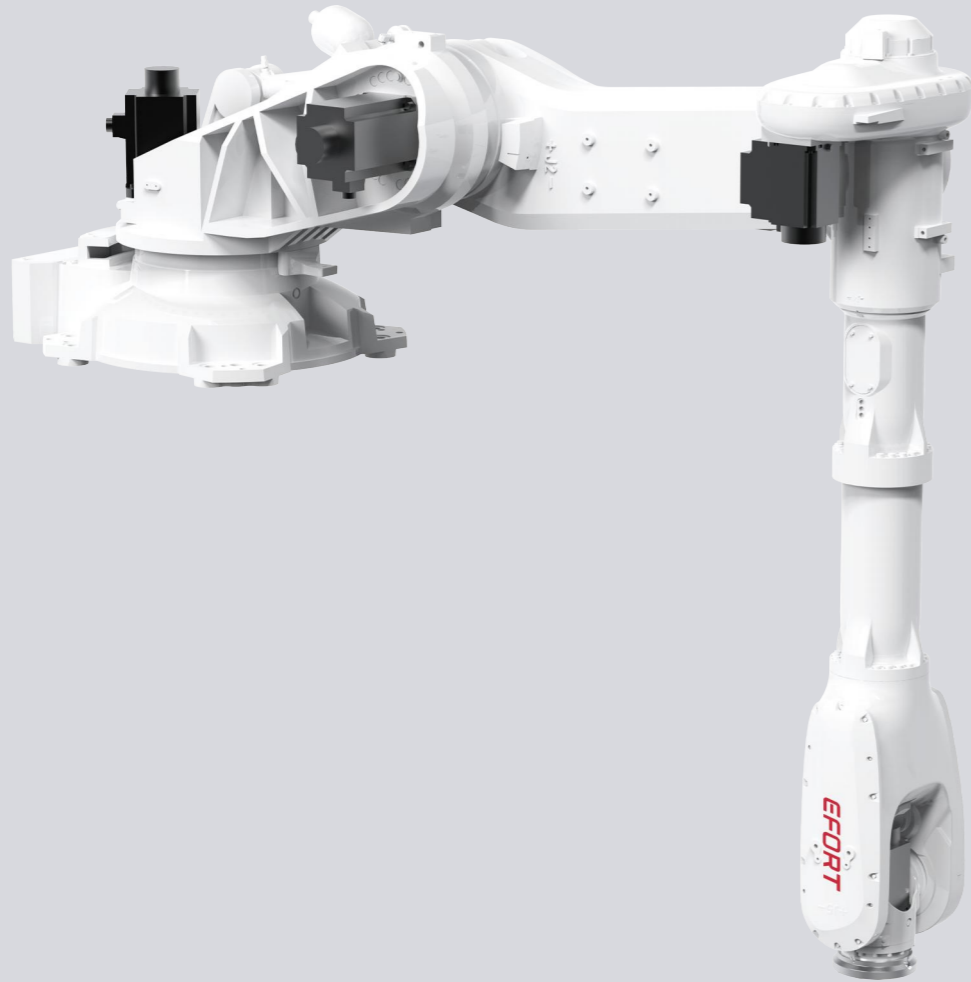

SPECIFICATIONS

Model	ER100P-3500	
Type	Articulated	
Controlled axes	6 Axes	
Max. payload on wrist	100 kg	
Repeatability	±0.1 mm	
Robot weight	1315 kg	
Reach	3502 mm	
Robot IP grade	IP65 / IP67 (Wrist)	
Cabinet IP grade	IP54	
Drive mode	AC servo drive	
Installation	Floor	
Installation enviroment	Ambient temperature	0~45 °C
	Ambient humidity	RH≤80% (No dew nor frost allowed)
	Vibration acceleration	4.9 m/s ² (<0.5 G)

Allowable load moment at wrist	J4	1324 N·m
	J5	1324 N·m
	J6	650 N·m
Allowable load inertia at wrist	J4	250 kg·m ²
	J5	250 kg·m ²
	J6	185 kg·m ²
Maximum speed	J1	130°/sec
	J2	110°/sec
	J3	115°/sec
	J4	170°/sec
	J5	120°/sec
	J6	220°/sec
Motion range	J1	±185°
	J2	+40°-160°
	J3	+180°-70°
	J4	±360°
	J5	±130°
	J6	±360°

OPERATING SPACE

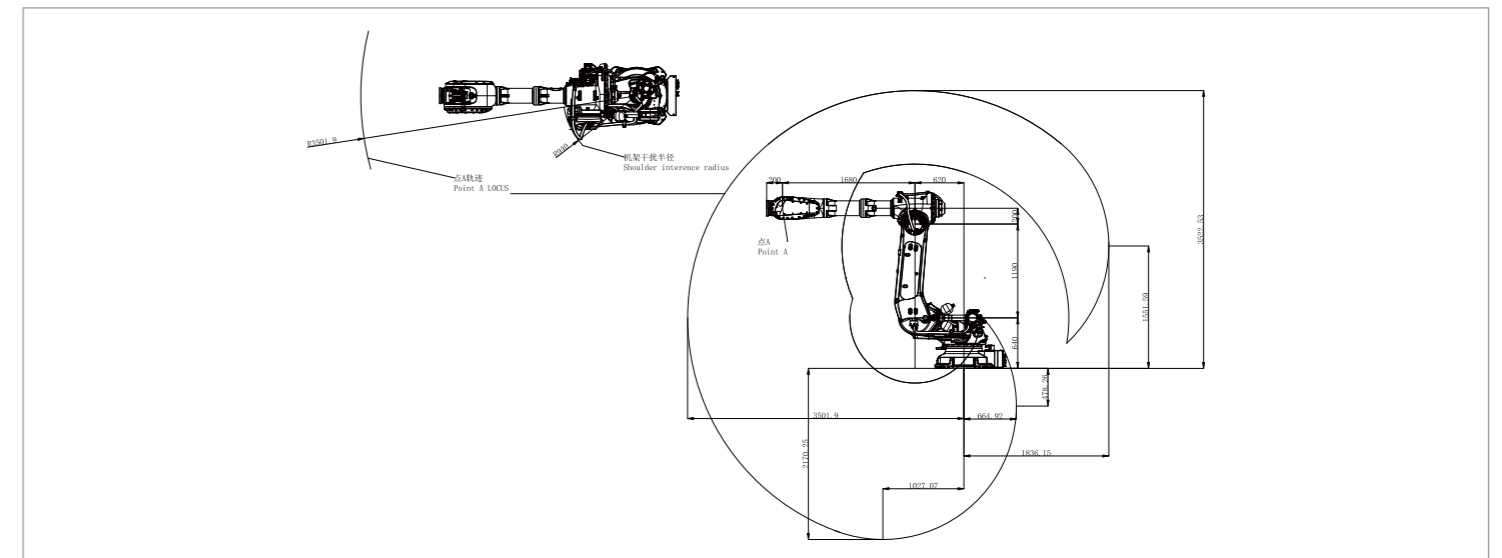

BASE MOUNTING SIZE

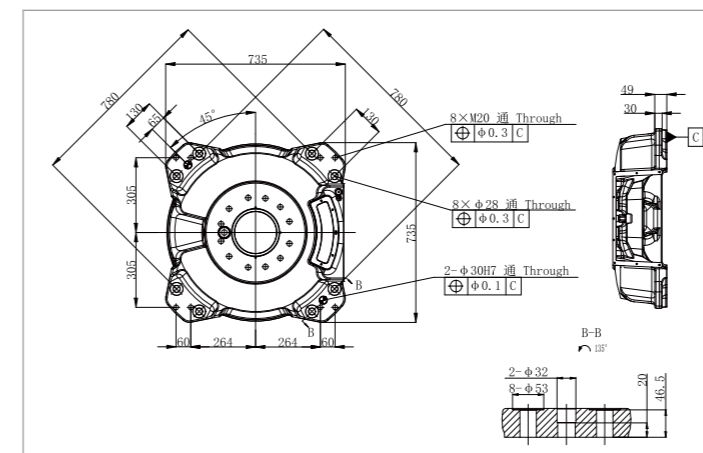

END FLANGE MOUNTING SIZE

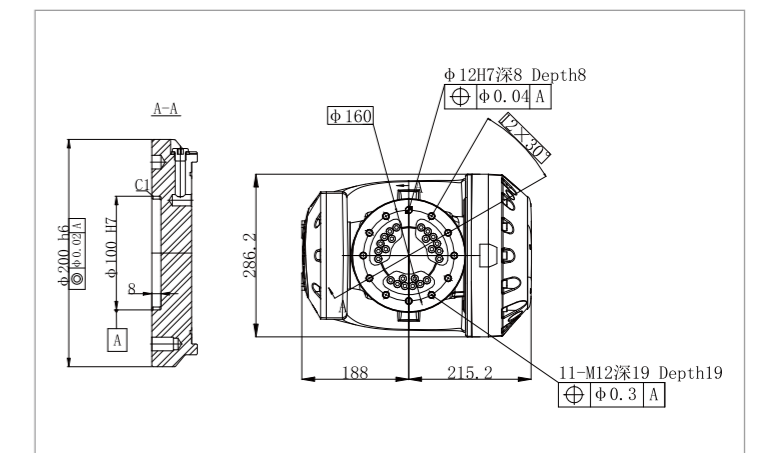

EFORT Intelligent Robot Co., Ltd.

PHONE: (00 86) 400-052-8877

ADDRESS: No.96 East Wanchun Road, China(Anhui) Pilot

Free Trade Zone Wuhu Area, Wuhu, Anhui Province, China

WWW.EFORT.COM.CN

*The final interpretation right belongs to EFORT Intelligent Robot Co., Ltd. Any updates will be made without prior notice.